

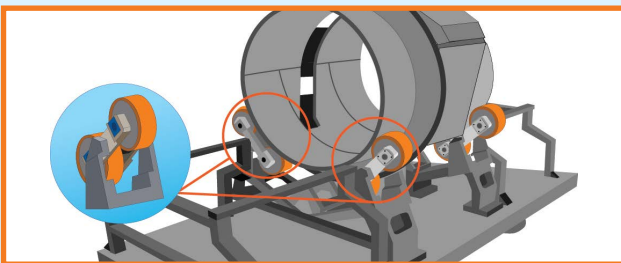

Product Overview

ConneCT combines Computed Tomography (CT) imaging with advanced explosive threat detection software. The technology allows airports and regulators to permit passengers to leave liquids and electronics in their bags at the screening checkpoints. **ConneCT** reduces the time required by each passenger to divest items resulting in dramatically increased passenger throughput. **ConneCT** features an innovative bearingless mechanical design to improve system reliability and lower the total cost of ownership.



CT Redefined: Reliable Bearingless Wheel Design



Highlights

- Full 3D, high resolution imaging for superior threat detection and low false alarms
- 2nd generation high speed CT technology designed to increase passenger throughput
- Innovative bearingless wheel design eliminates the need to replace costly bearings, lowering the cost of ownership, and dramatically improving system reliability
- Industry's first intuitive touchscreen workstation
- Integrates with leading automated tray return and baggage handling systems
- Compact footprint - easy for airports to upgrade to ConneCT from current 2D X-ray scanners
- Interoperable network architecture supports checkpoint and hold baggage operations, remote image analysis, and system monitoring
- Open architecture ready for 3rd party algorithms





Specifications

Physical Specifications

DIMENSIONS	L	2,692 mm (106 in)
	W	1,444 mm (56.9 in)
	H	1,676 mm (66 in)
TUNNEL SIZE	W	620 mm (24.4 in)
	H	420 mm (16.5 in)
WEIGHT (scanner only)		1,965 kg (4,333 lbs)
MAX BAG SIZE		100 cm (39.37 in)

Environment & Power

OPERATING TEMP	0 to 40 C (32-104 F)
OPERATING HUMIDITY	10 to 90%, non-condensing
STORAGE TEMP	-20 to 50 C (0-120 F)
POWER CONSUMPTION	2.69 kVA
POWER REQUIREMENT	208/230VAC
X-RAY VOLTAGE	160 kV, 5mA
DUTY CYCLE	100%
OPERATING NOISE LEVEL	<70dB
COMPUTER OS	Linux

Performance

CONVEYOR SPEED	15 cm (5.9 in) per sec
MAX CONVEYOR LOAD	23 kg (50 lb) per tray
OPERATIONAL THROUGHPUT	>500 bags per hour

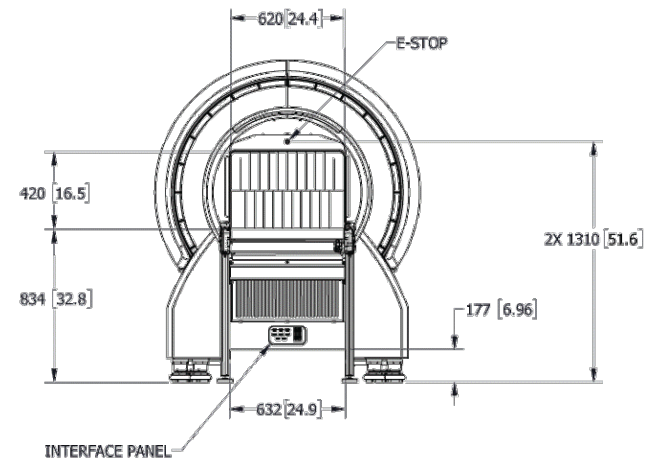
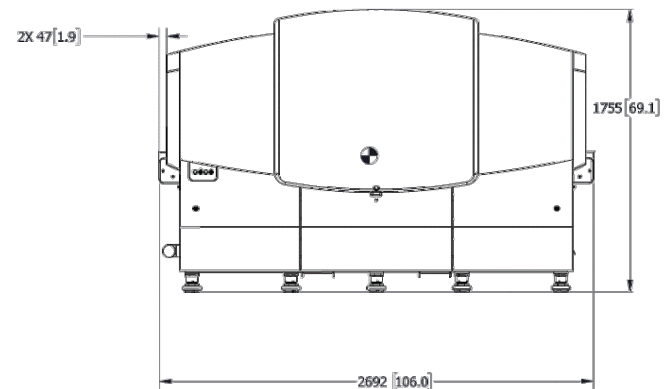

The information contained in this datasheet is subject to change without notice. This datasheet is intended for marketing purposes only and in no event shall it be used or included in a resulting contract between Analogic and customer. Actual products delivered may not include all the features and capabilities shown. Analogic disclaims any and all warranties if the information in this data sheet is inaccurate. Final determination of the suitability of Analogic's products for any application or the manner of its use is the customer's sole responsibility.